

WLs180-06 (cementownia Groszowice)

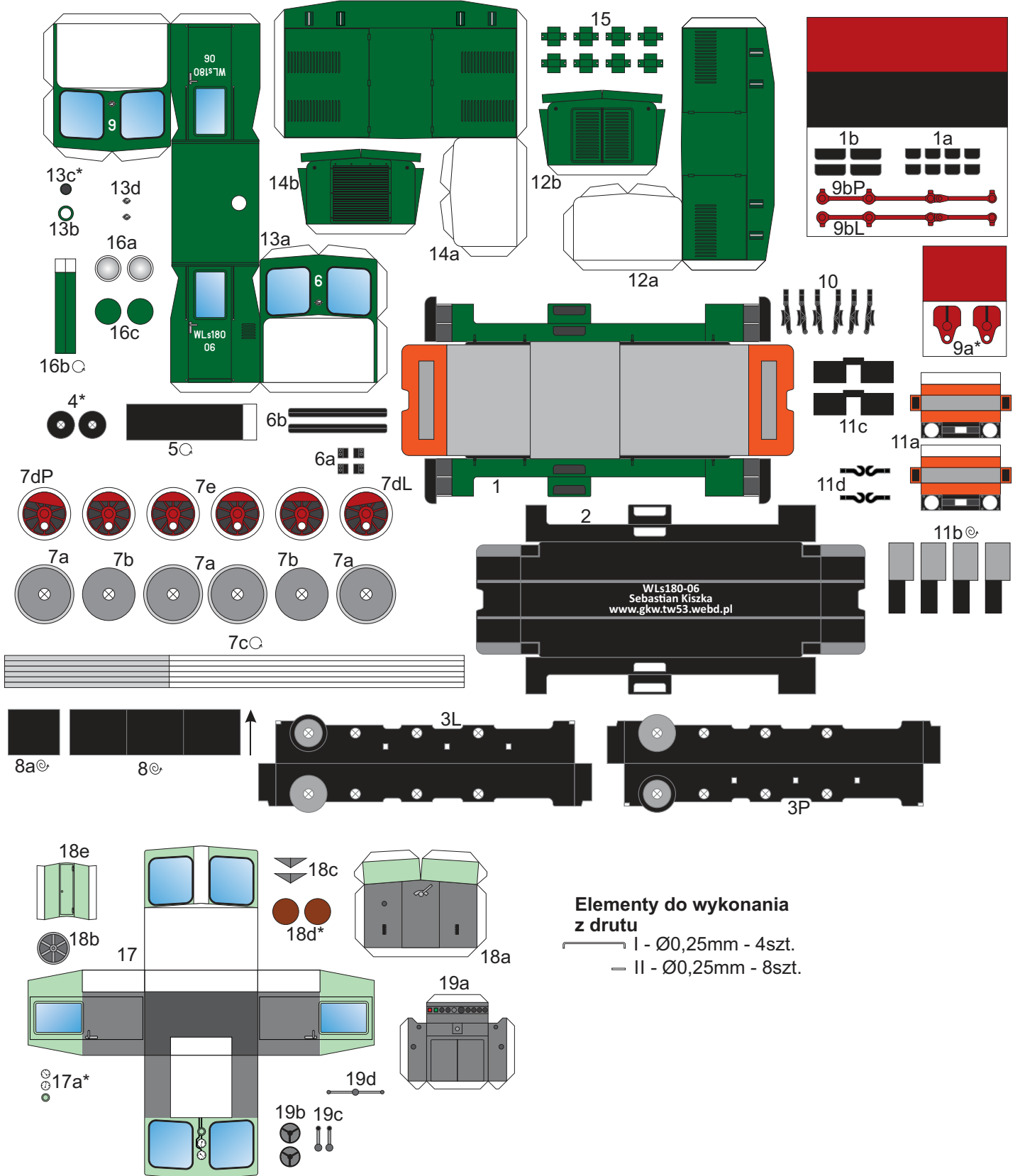

WLs180-13 (cementownia Groszowice)

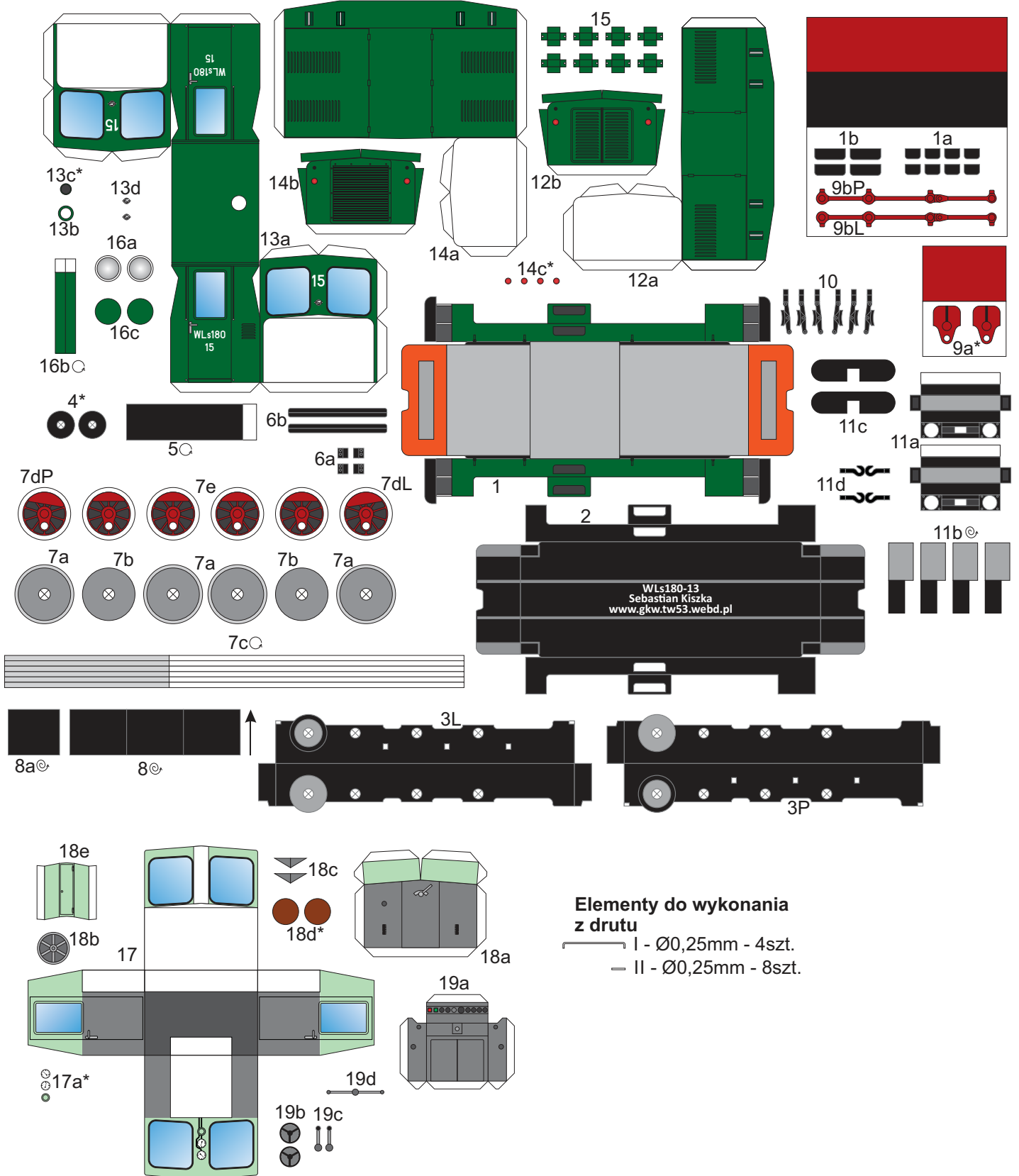

WLs180-16 (cementownia Groszowice)

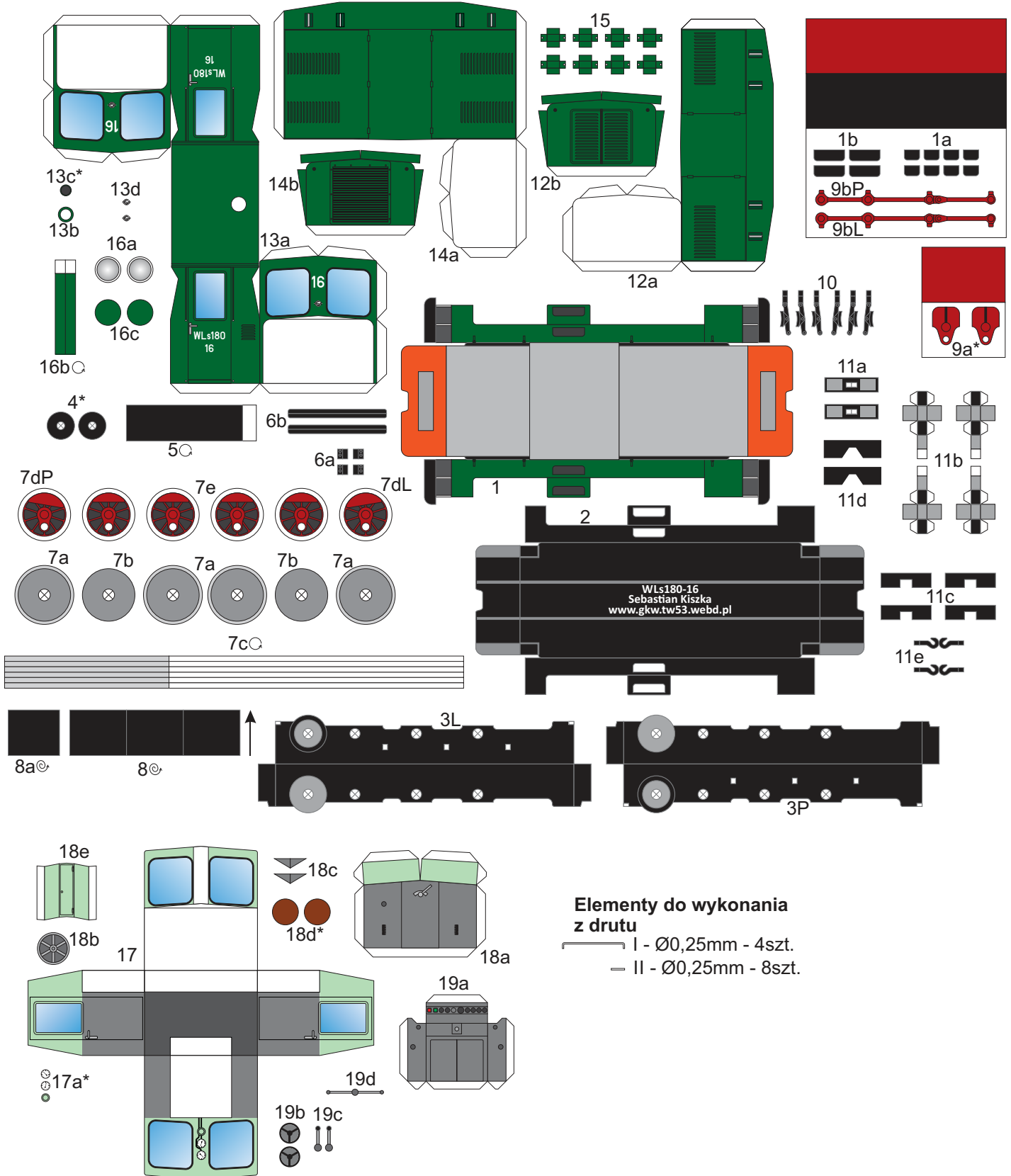

WLs180-40 (cementownia Groszowice)

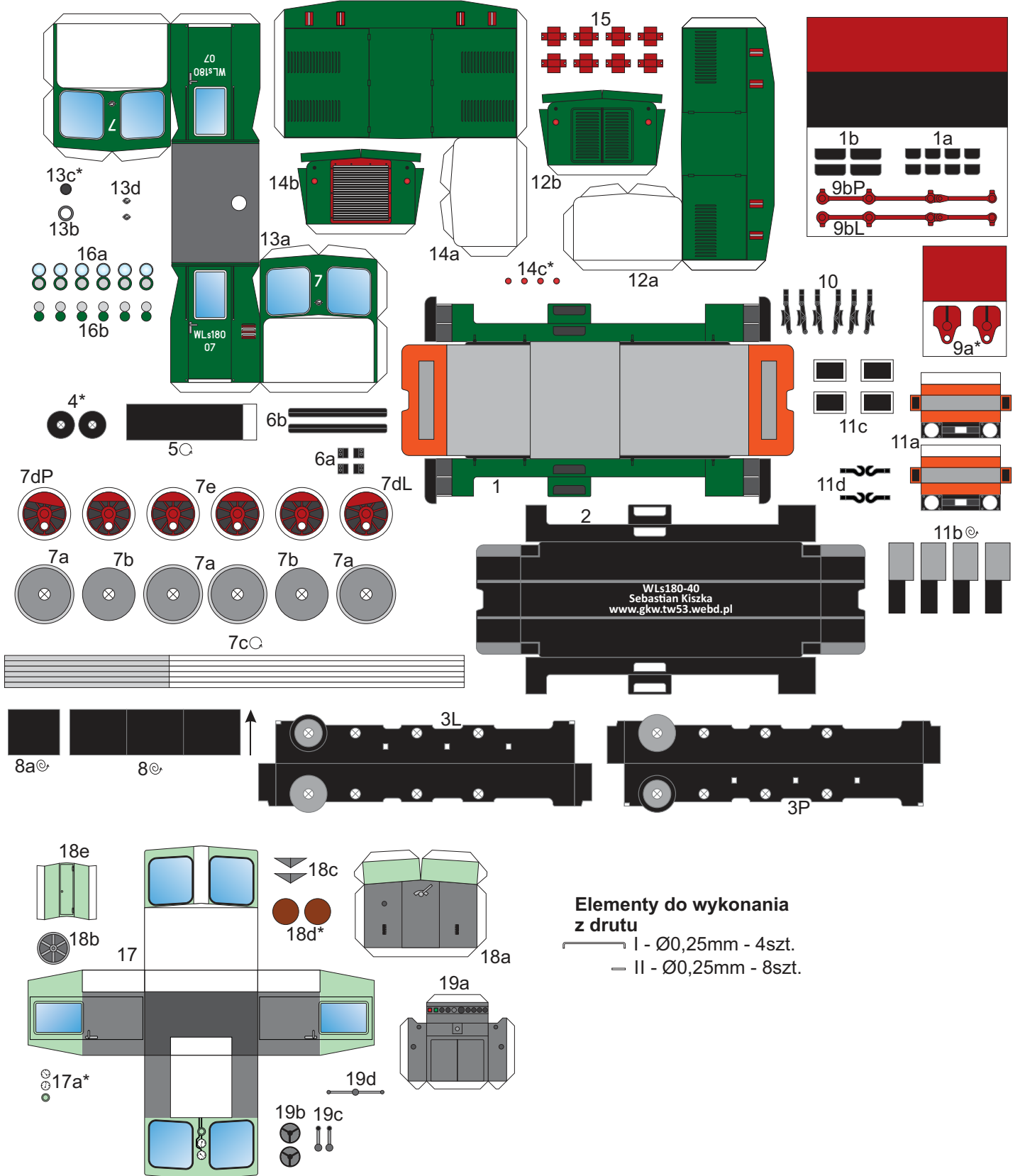

Instrukcja

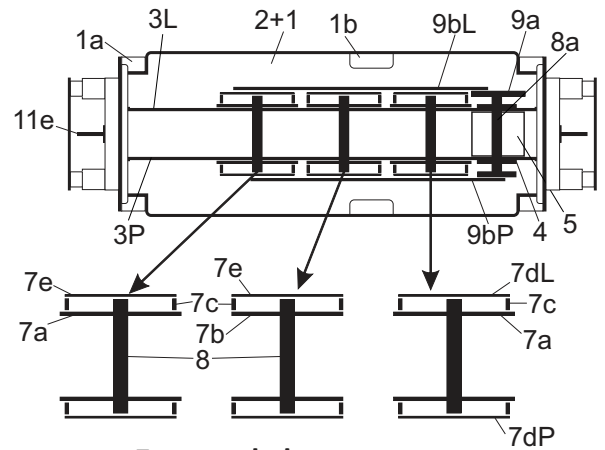
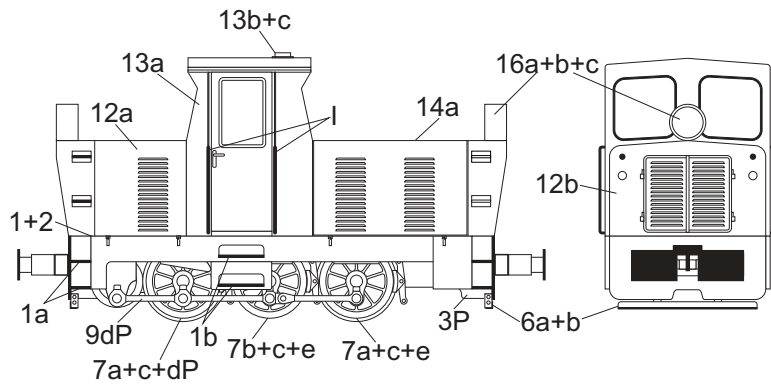

Zestawy kołowe (skala 1,5:1)

Umieszczenie reflektorów dla WLS180-40 (7)

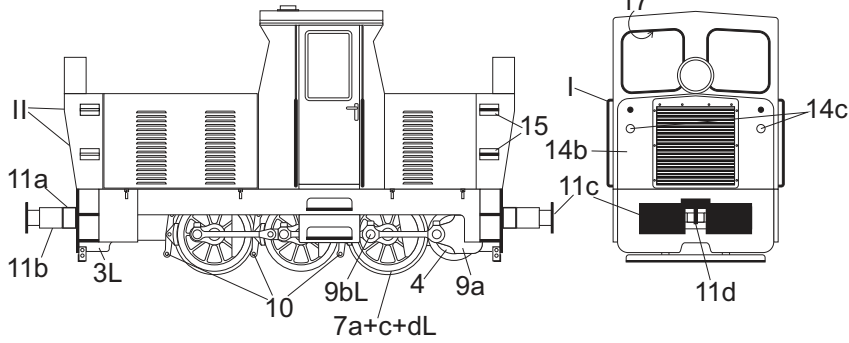
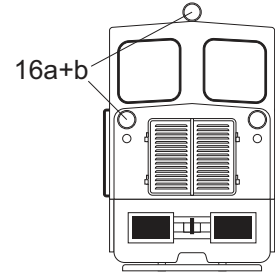

Wnętrze kabiny (skala 1,5:1)

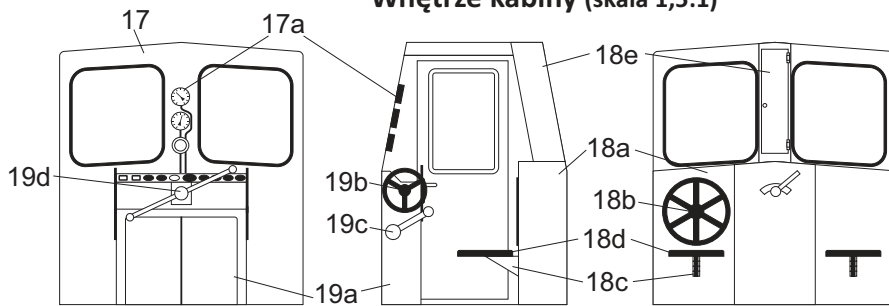

Sprzęgi dla WLS180-16

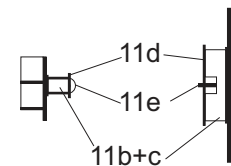
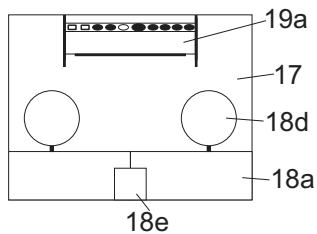
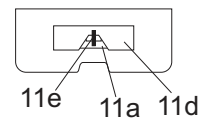

Objaśnienia

- *^b - podkleić brystolem
- * - podkleić kartonem 0,5mm
- ⦿ - zwinąć w wałek (widoczny tylko fragment zabarwiony)
- ⦿ - zwinąć ciasno
- - kierunek zwijania
- ⦿¹⁷ - część po wewnętrznej stronie