

1

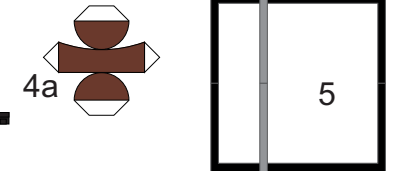

Instrukcja

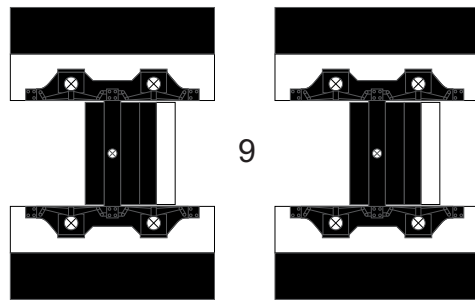
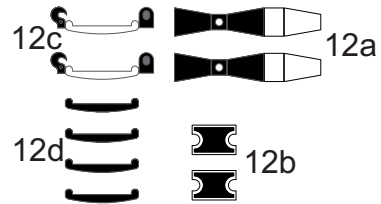
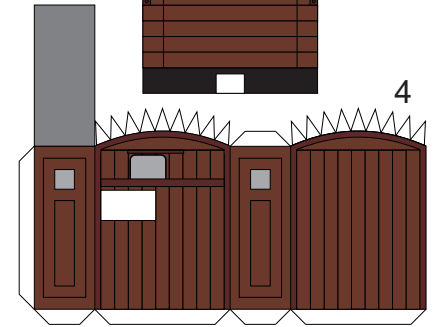
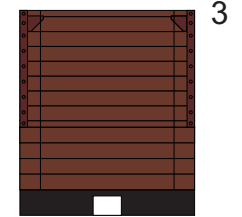
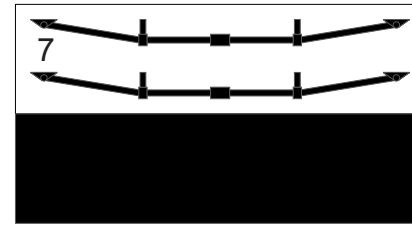
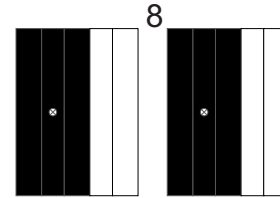
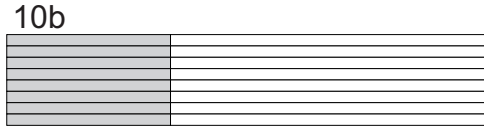
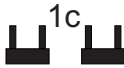
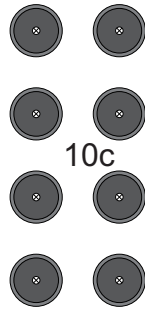
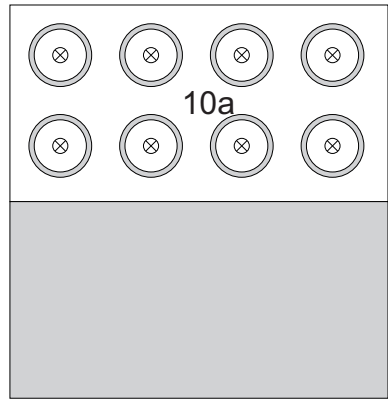
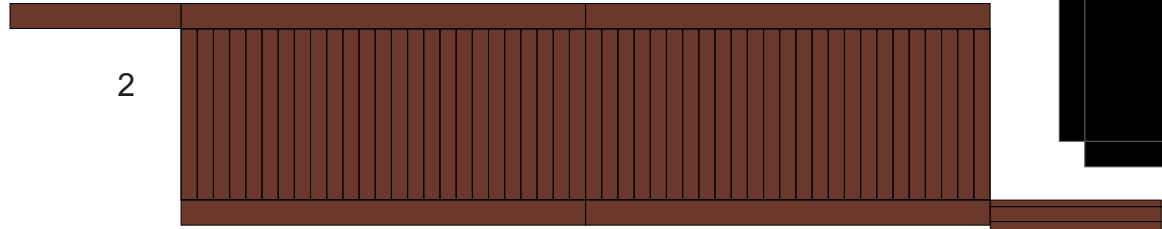
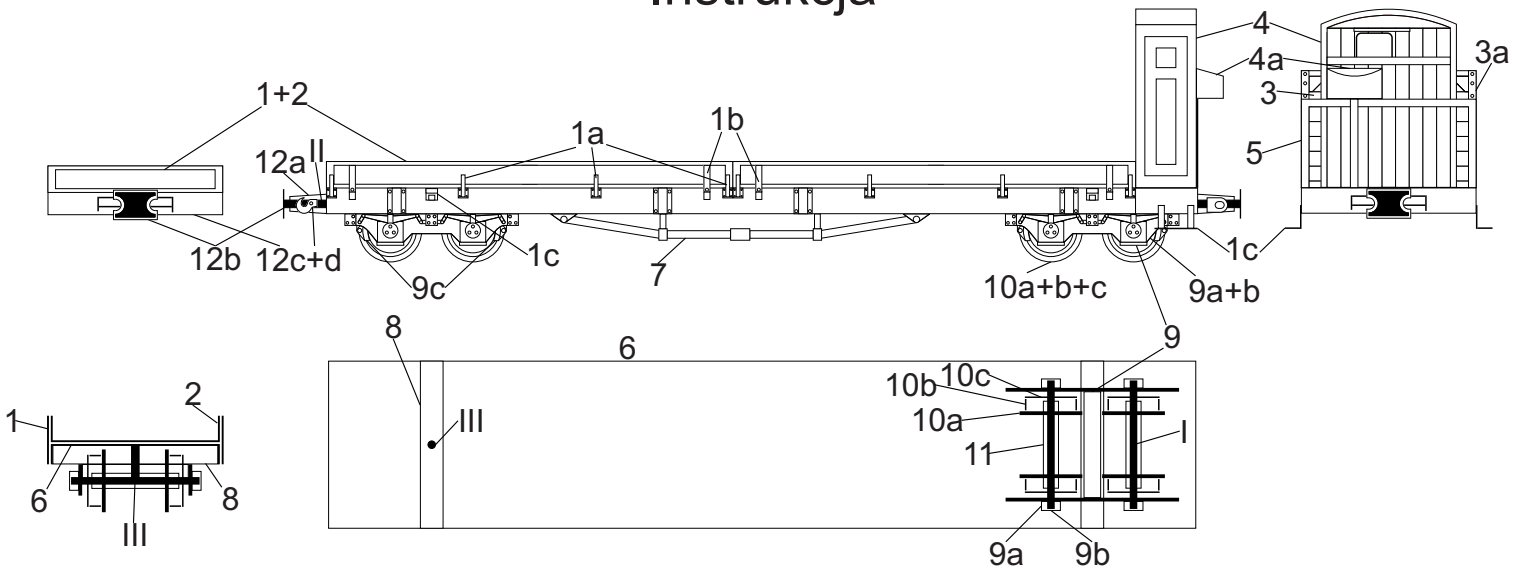

Części 9c ukształtować w następujący sposób:

Wzory elementów do wykonania z drutu

I - Ø1mm - 4szt.

II - Ø1mm - 2szt.

III - Ø1mm - 2szt.

