

# KJ-Lyd2-01

## KWK Janina (750mm)

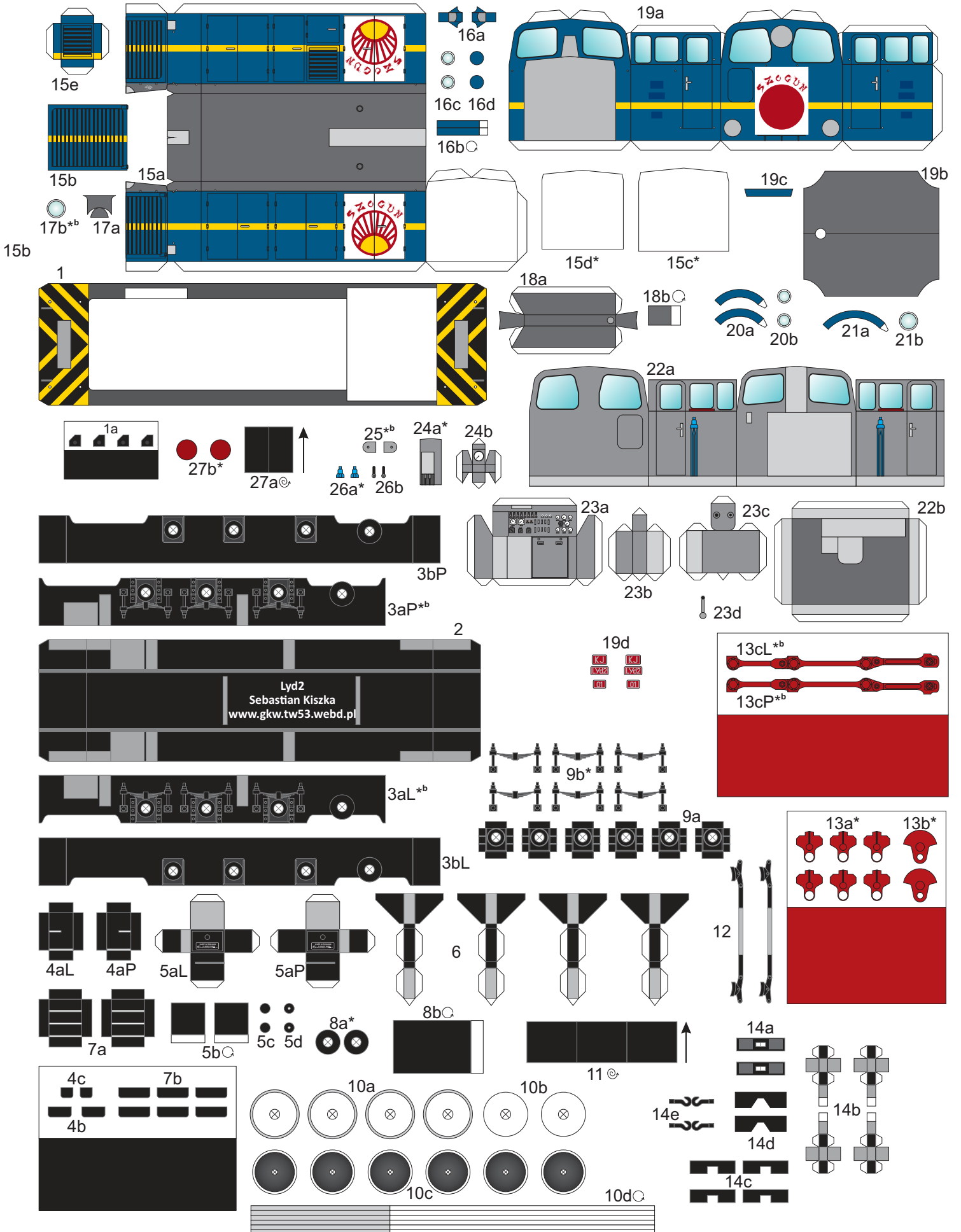

# KJ-Lyd2-01 (końcowy okres eksploatacji) KWK Janina (750mm)

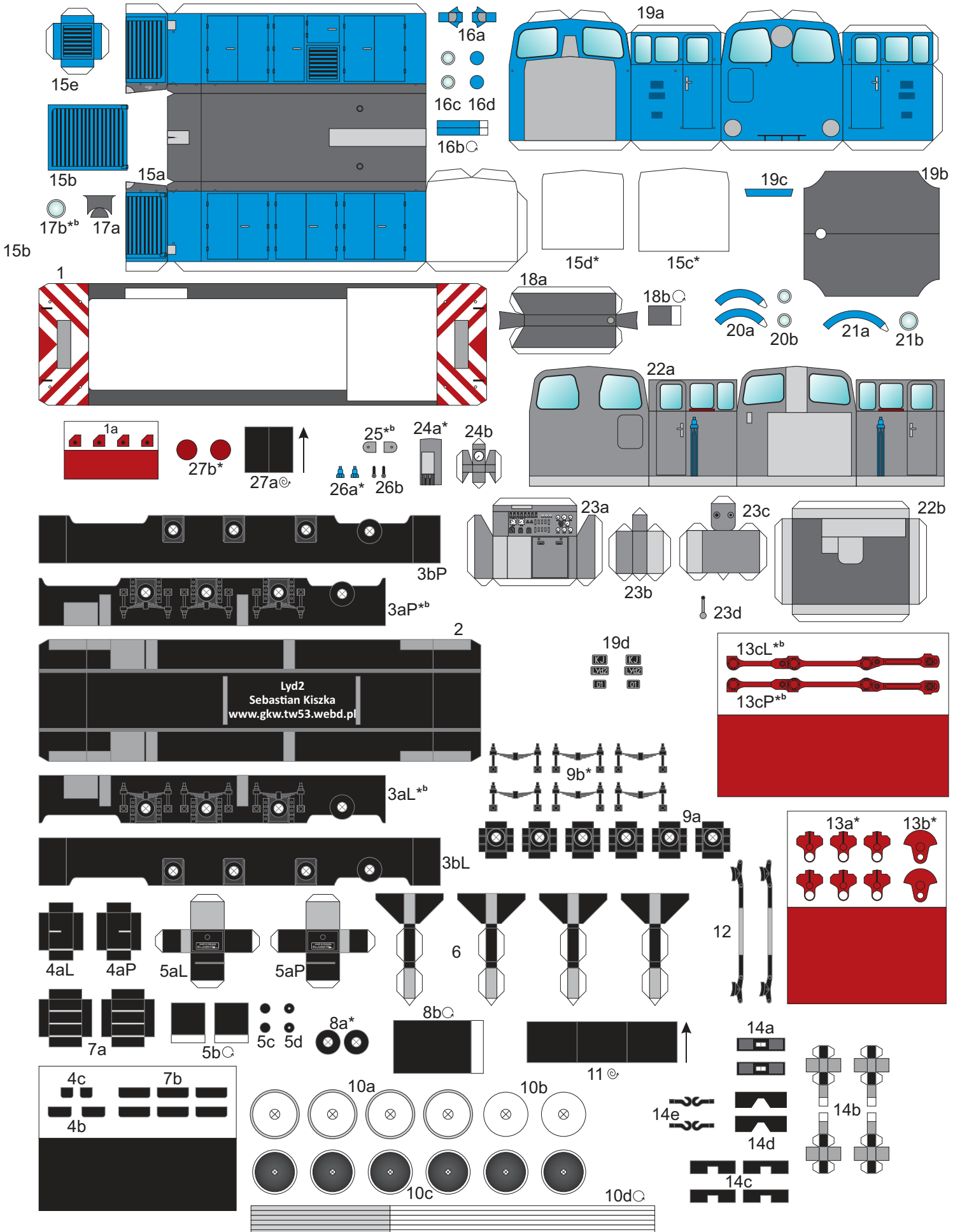

# KJ-Lyd2-02

## KWK Janina (750mm)

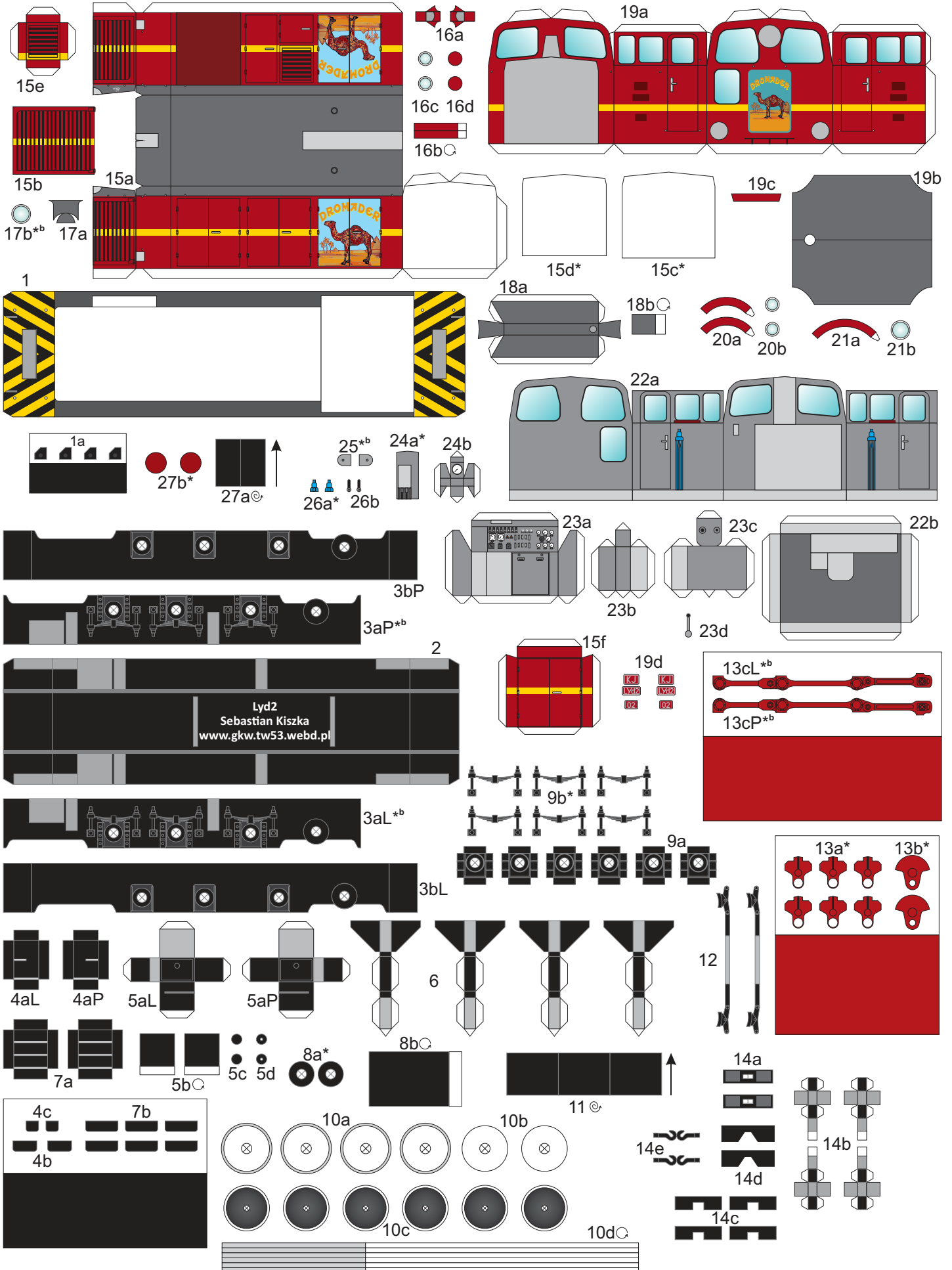

# Instrukcja

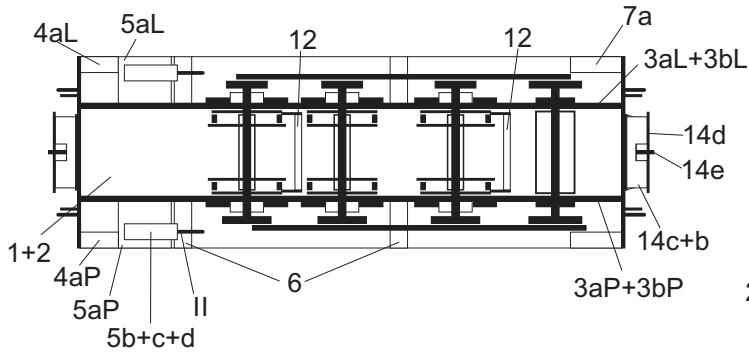
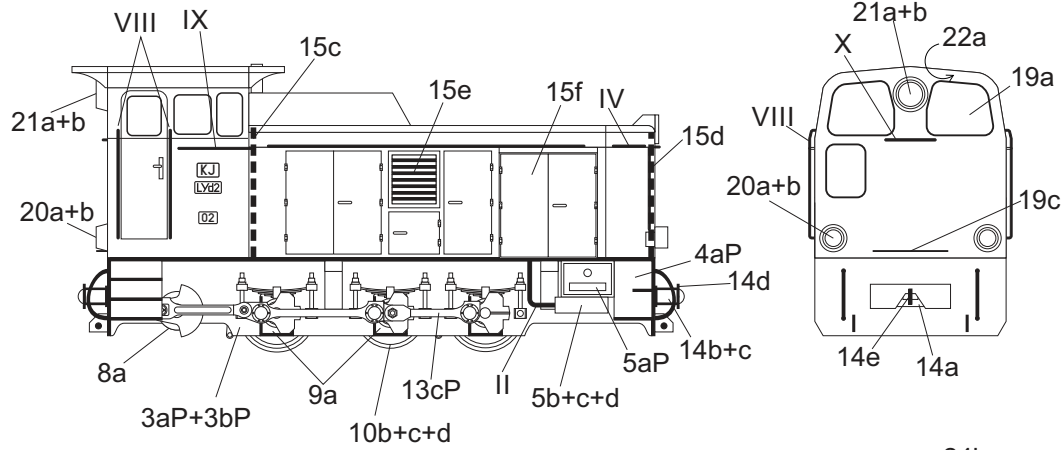
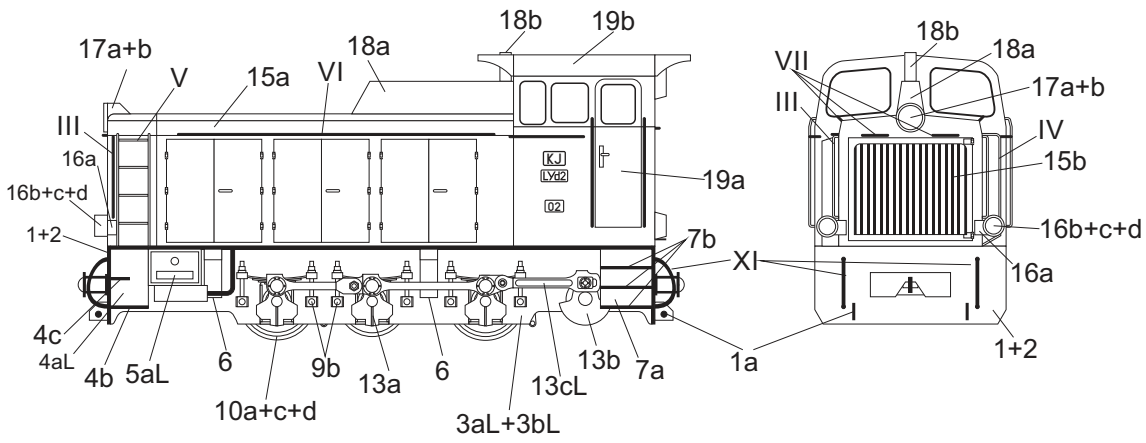

**Zestawy kołowe (skala 1,5:1)**

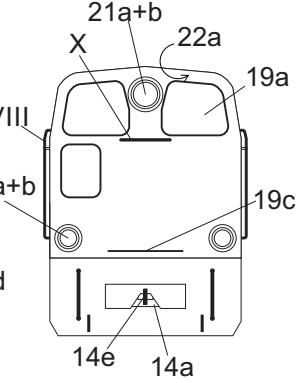
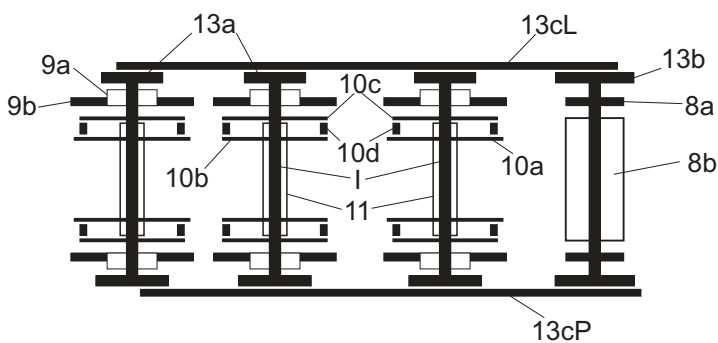

## Wnętrze kabiny

(skala 1,5:1)

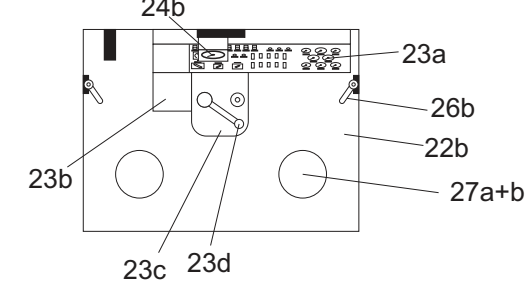
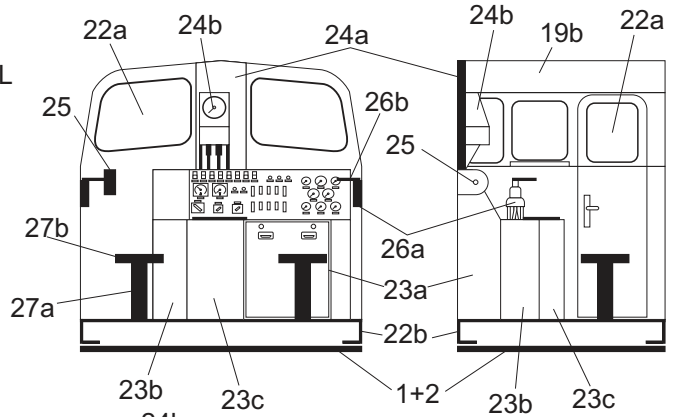

## Elementy do wykonania z drutu

- I - Ø1,00mm - 4szt.
- II - Ø0,50mm - 2szt.
- III - Ø0,25mm - 2szt.
- IV - Ø0,25mm - 1szt.
- VI - Ø0,25mm - 2szt.
- VII - Ø0,25mm - 2szt.
- VIII - Ø0,25mm - 4szt.
- IX - Ø0,25mm - 2szt.
- X - Ø0,25mm - 1szt.

## Objaśnienia

- \*<sup>b</sup> - podkleić brystolem
- \* - podkleić kartonem 0,5mm
- ⊖ - zwinąć w wałek (widoczny tylko fragment zabarwiony)
- ⊙ - zwinąć ciasno
- - kierunek zwijania
- ↺<sup>22a</sup> - część po wewnętrznej stronie

V - Ø0,25mm - 1szt.



XI - Ø0,50mm - 4szt.