

Lyd2-103

PKP (750mm)

(malowanie fabryczne)

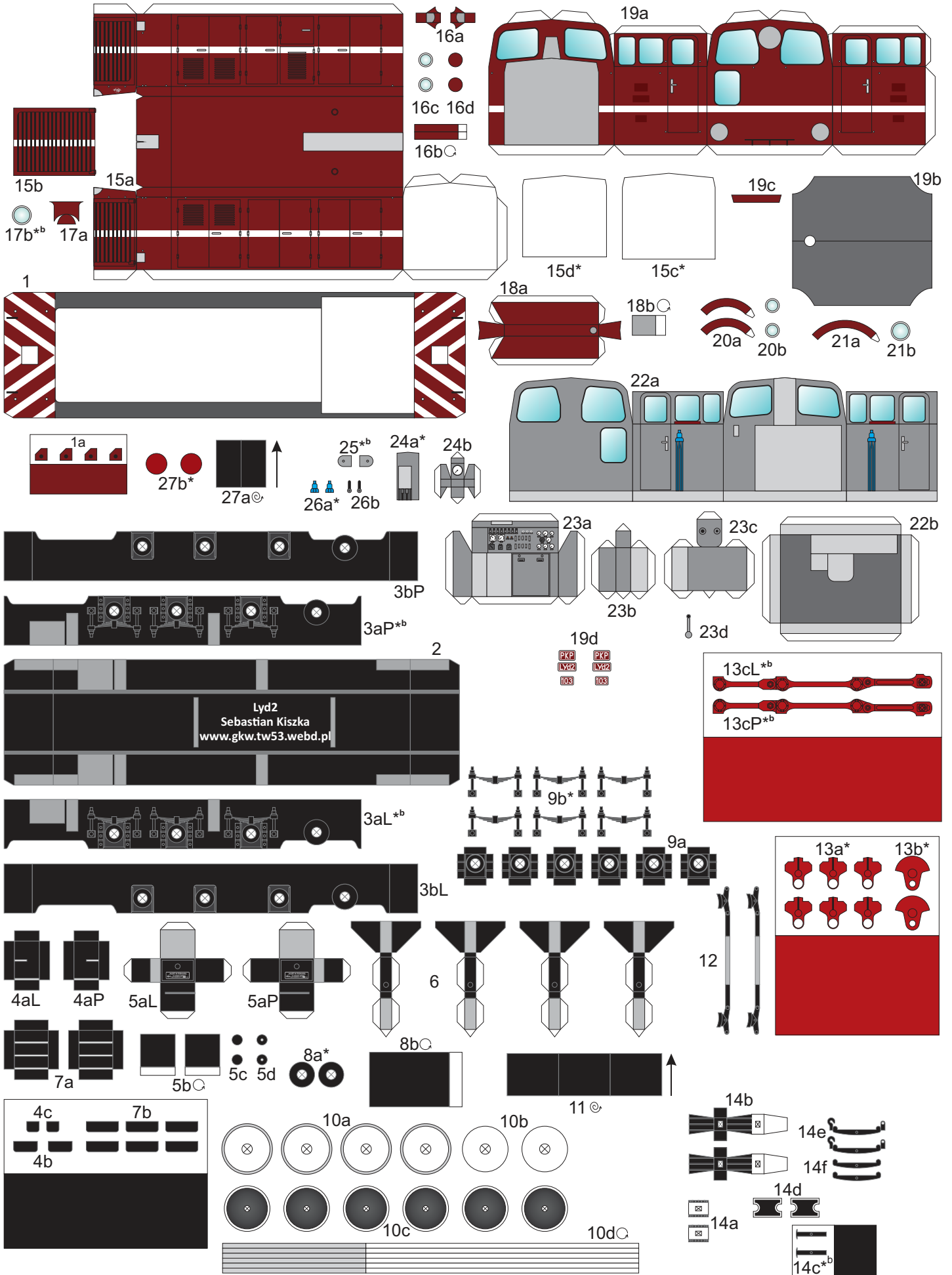

Lyd2-103

PKP (750mm)

(malowanie po naprawie głównej w Rumunii w latach 80-tych)

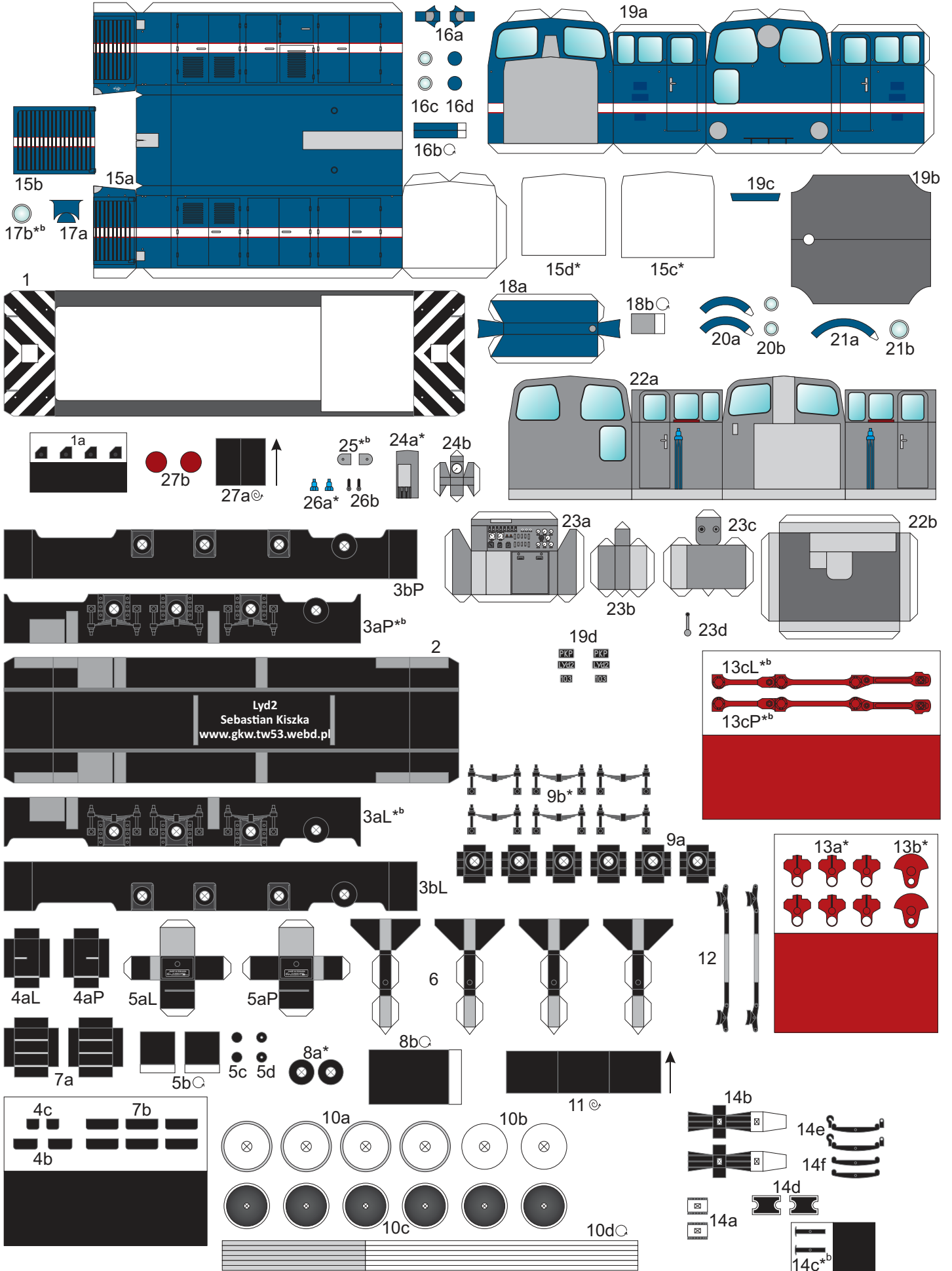

Lyd2-103 Cukrownia Zbiersk (750mm)

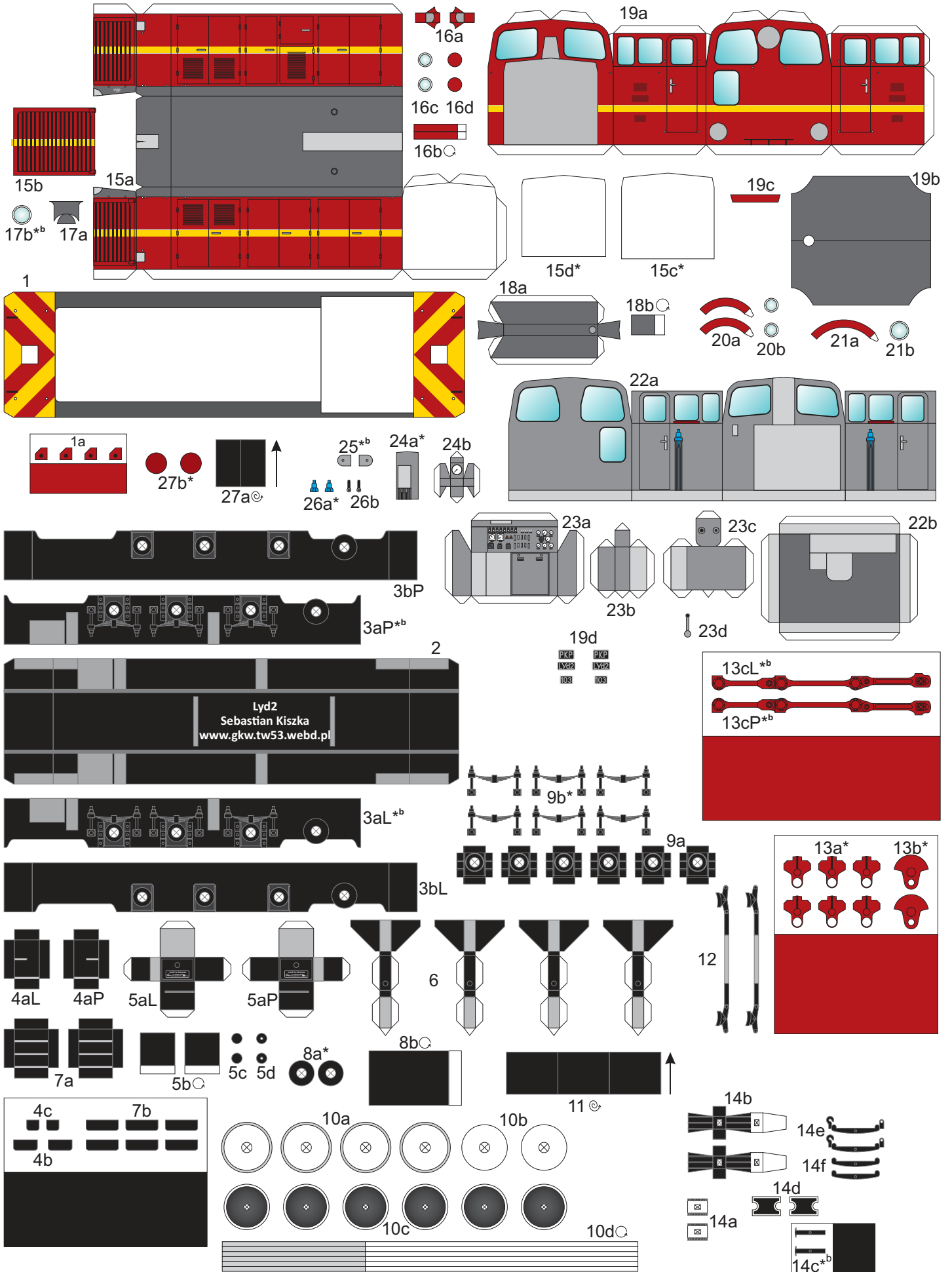

Instrukcja

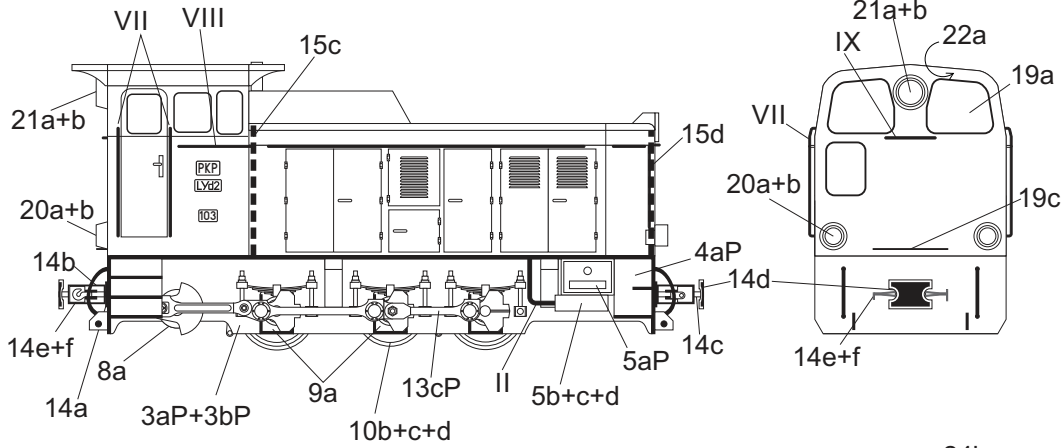
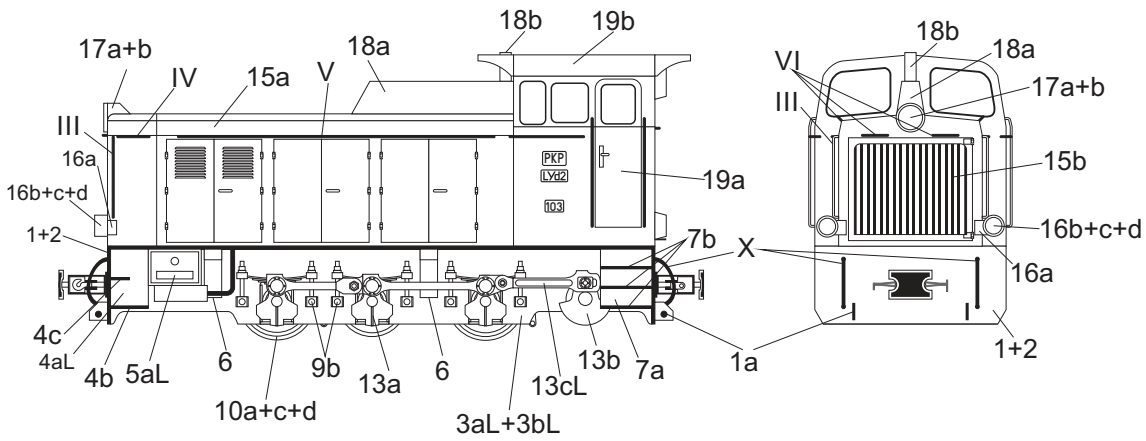

Wnętrze kabiny

(skala 1,5:1)

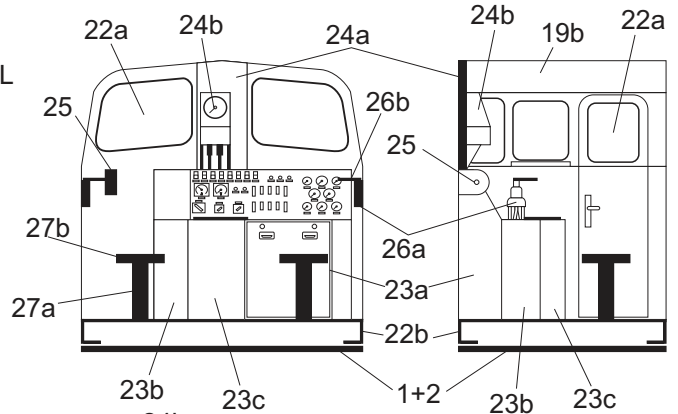



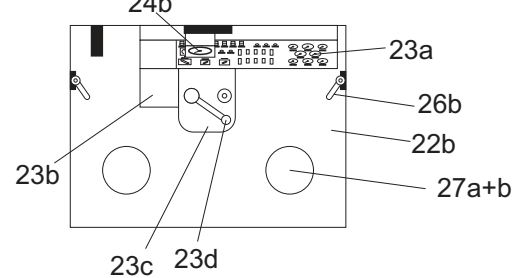
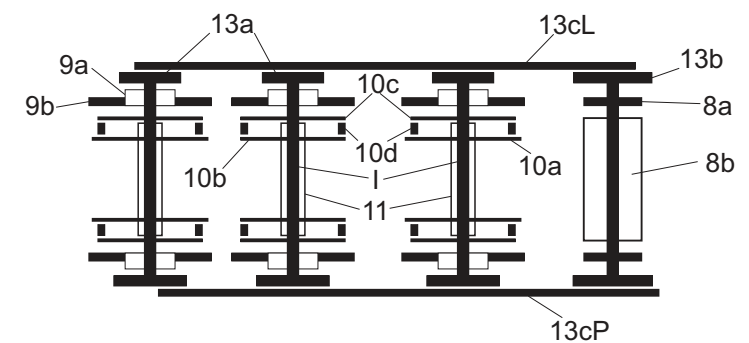







Zestawy kołowe (skala 1,5:1)



Objaśnienia

- *^b - podkleić brystolem
- * - podkleić kartonem 0,5mm
- ⊙ - zwinąć w wałek (widoczny tylko fragment zabarwiony)
- ⊙ - zwinąć ciasno
- - kierunek zwijania
- ↺^{22a} - część po wewnętrznej stronie

Elementy do wykonania z drutu

-  I - Ø1,00mm - 4szt.
-  II - Ø0,50mm - 2szt.
-  III - Ø0,25mm - 2szt.
-  IV - Ø0,25mm - 2szt.
-  V - Ø0,25mm - 2szt.
-  VI - Ø0,25mm - 2szt.
-  VII - Ø0,25mm - 4szt.
-  VIII - Ø0,25mm - 2szt.
-  IX - Ø0,25mm - 1szt.
-  X - Ø0,50mm - 4szt.