

1

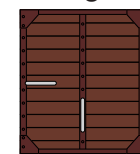

Instrukcja

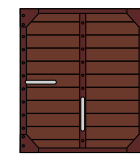
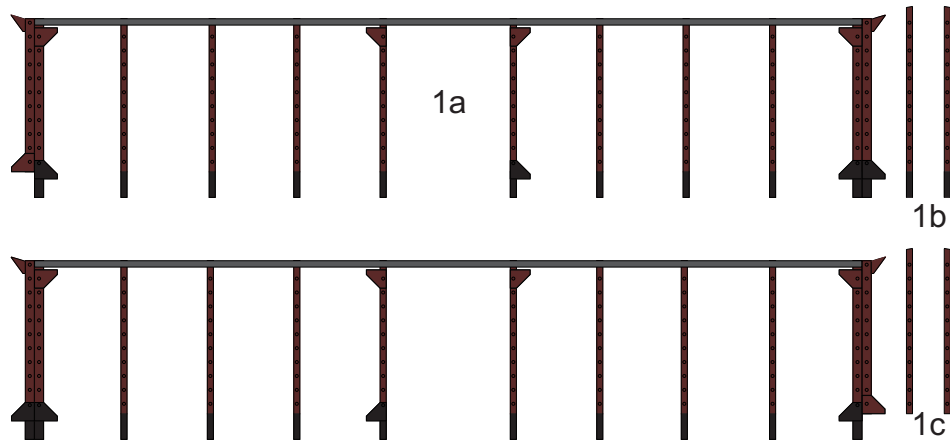
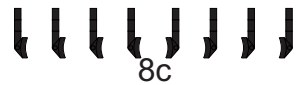
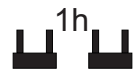
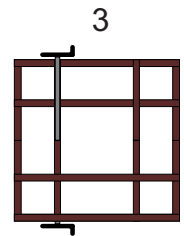
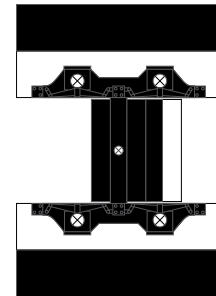
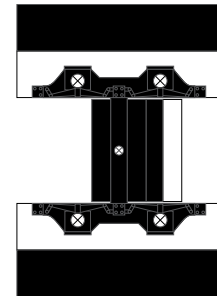
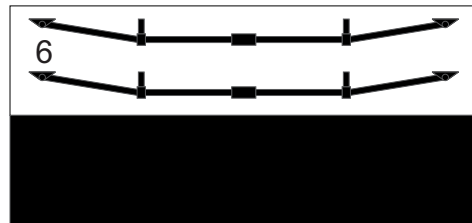
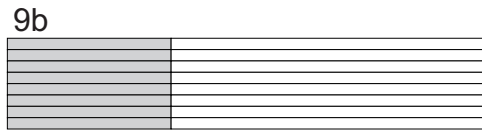
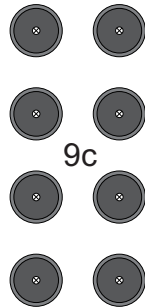
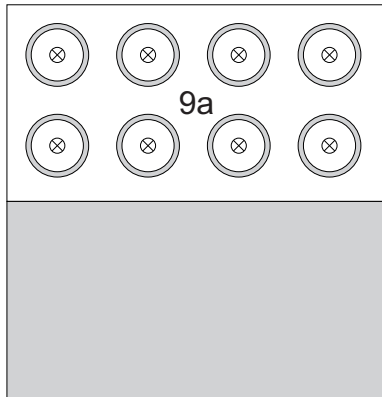
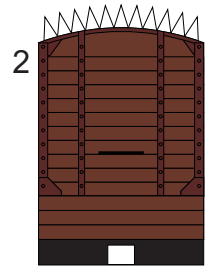
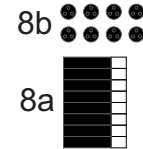
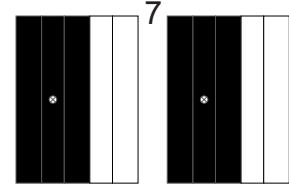
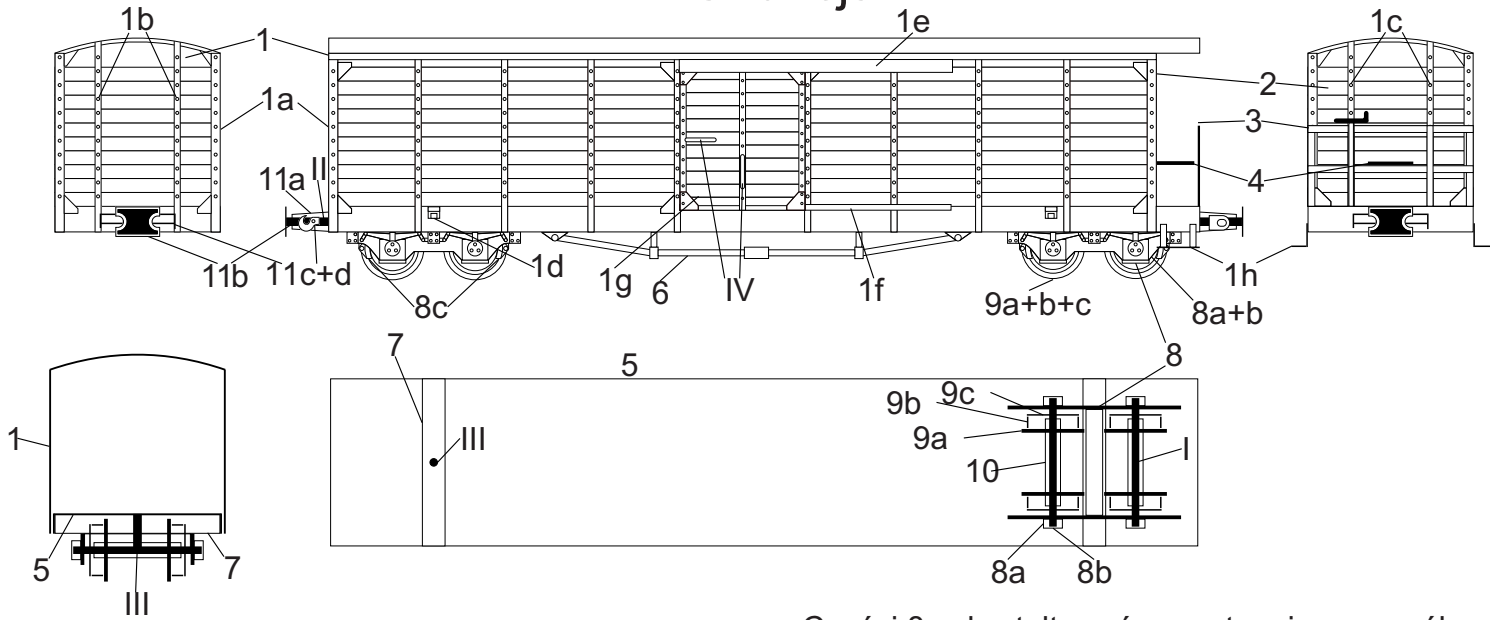

Części 8c ukształtować w następujący sposób:

Wzory elementów do wykonania z drutu

I - Ø1mm - 4szt.

II - Ø1mm - 2szt.

III - Ø1mm - 2szt.

IV - Ø0,5mm - 4szt.

