

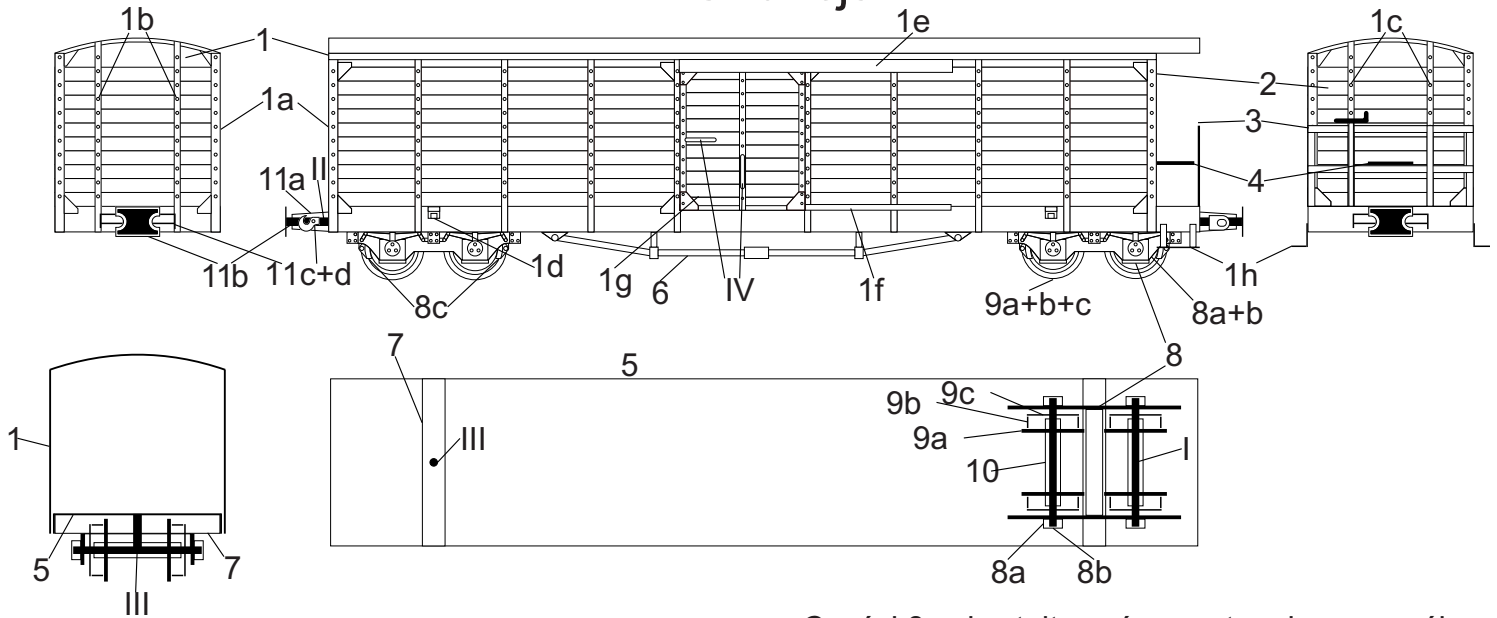

Instrukcja



Części 8c ukształtować w następujący sposób:

Wzory elementów do wykonania z drutu

 I - Ø1mm - 4szt.

 II - Ø1mm - 2szt.

 III - Ø1mm - 2szt.

[IV - Ø0,5mm - 4szt.

